

Serie EK
Forma costruttiva in due parti (A)

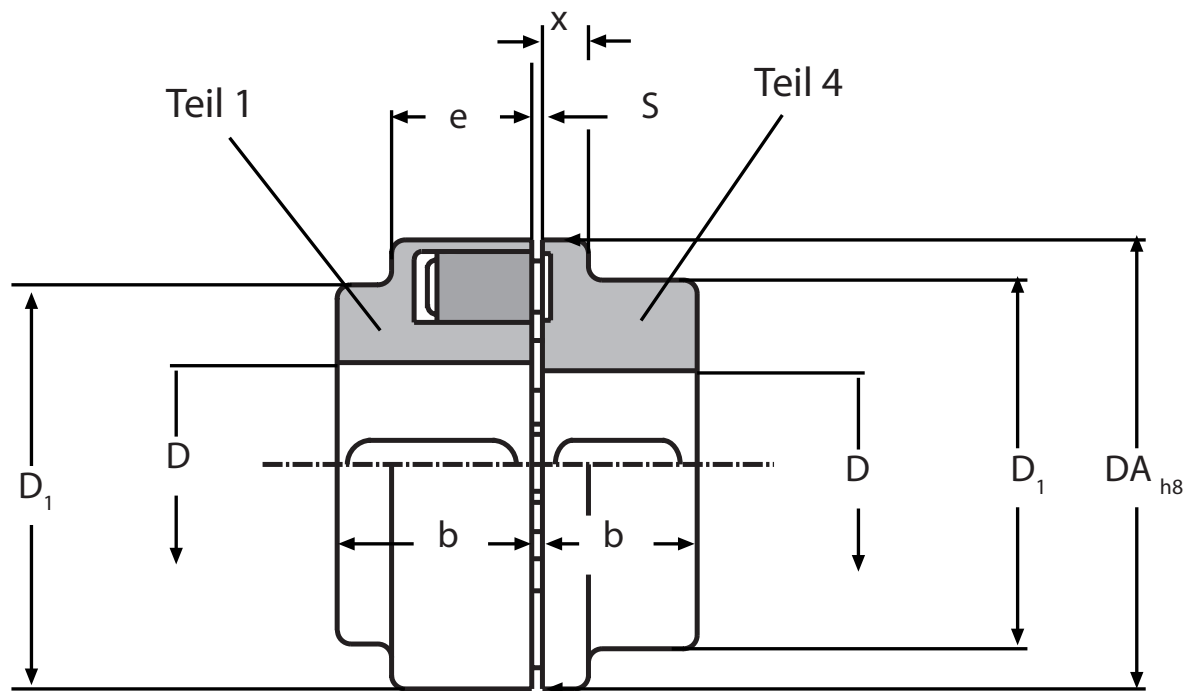

Forma A

Sigla giunto	Giri max [1/min]	Momento torcente [Nm]	Potenza nominale [kW]	Momento d'inerzia [kgm ²]	Massa [kg]	Numero inserti in gomma	Parte 1			Parte 4			D _A	x	b	e	s
							D ₁	D _{min}	D _{max}	D ₁	D _{min}	D _{max}					
EK 58 A	5000	19	0,002	0,0002	0,45	4	58	8	19	40	8	24	58	8	20	20	2-4
EK 68 A	5000	34	0,0036	0,0003	0,63	5	68	8	24	46	8	28	68	8	20	20	2-4
EK 80 A	5000	60	0,0063	0,0012	1,5	6	80	10	30	68	10	38	80	10	30	30	2-4
EK 95 A	5000	100	0,011	0,0027	2,6	6	95	11	42	76	11	42	76	12	35	30	2-4
EK 110 A	5000	160	0,017	0,0055	4	6	110	14	48	86	14	48	86	14	40	34	2-4
EK 125 A	5000	240	0,025	0,0107	6,1	6	125	16	55	90	16	55	90	18	50	32	2-4
EK 140 A	4900	360	0,038	0,014	7	6	140	18	60	100	18	60	100	20	55	34	2-4
EK 160 A	4250	560	0,059	0,025	9,4	7	160	22	65	108	22	65	108	20	60	39	2-6
EK 180 A	3800	880	0,092	0,045	14	8	180	24	75	125	24	75	125	20	70	42	2-6
EK 200 A	3400	1340	0,14	0,08	20	8	200	28	85	140	28	85	140	24	80	47	2-6
EK 225 A	3000	2000	0,21	0,135	24	8	225	38	90	150	38	90	150	18	90	52	2-6
EK 250 A	2750	2800	0,29	0,23	34	8	250	48	-100	165	48	100	165	18	100	60	3-8
EK 280 A	2450	3900	0,41	0,37	45	8	280	55	-110	180	55	110	180	20	110	65	3-8

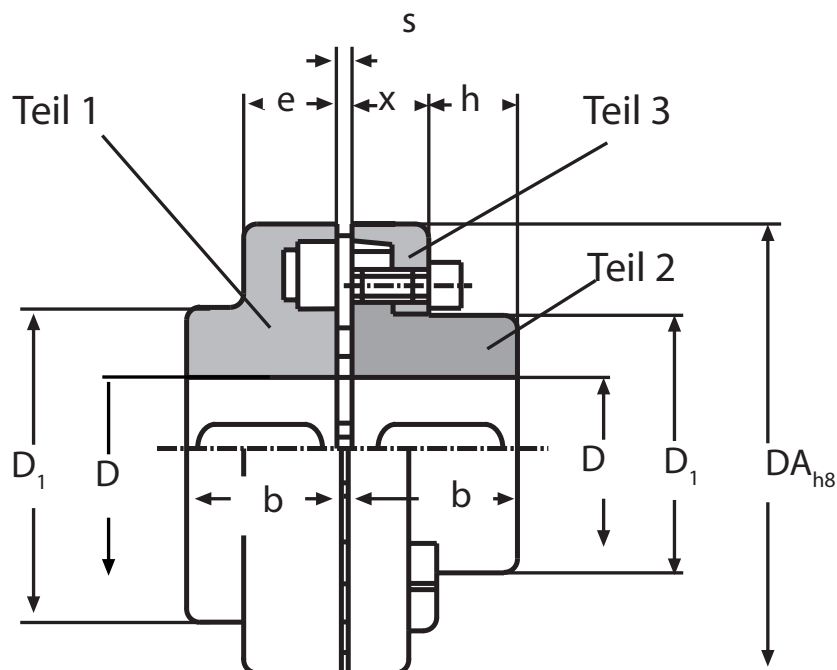

Forma B

Sigla giunto	Giri max [min ⁻¹]	Momento torcente [Nm]	Potenza nominale [kW]	Momento d'inerzia [kgm ²]	Massa [kg]	Numero inserti in gomma	Parte 1			Parte 4				x	b	e	h	s
							D ₁	D _{min}	D _{max}	D ₁	D _{min}	D _{max}	D _A					
EK 110 B	5000	160	0,017	0,0047	3,5	6	86	14	48	62	14	38	110	20	40	34	33	2-4
EK 125 B	5000	240	0,025	0,0095	5,6	6	90	16	55	75	16	45	125	23	50	32	38	2-4
EK 140 B	4900	360	0,038	0,015	7	6	100	18	60	82	18	50	140	28	55	34	43	2-4
EK 160 B	4250	560	0,059	0,028	9,8	7	108	22	65	95	22	58	160	28	60	39	47	2-6
EK 180 B	3800	880	0,092	0,049	14,2	8	125	24	75	108	24	65	180	30	70	42	50	2-6
EK 200 B	3400	1340	0,14	0,085	19,8	8	140	28	85	122	28	75	200	32	80	47	53	2-6
EK 225 B	3000	2000	0,21	0,15	27	8	150	38	90	138	24	85	225	38	90	52	61	2-6
EK 250 B	2750	2800	0,29	0,25	37	8	165	48	100	155	32	95	250	42	100	60	69	3-8
EK 280 B	2450	3900	0,41	0,4	48	8	180	55	110	172	55	105	280	42	110	65	73	3-8
EK 315 B	2150	5500	0,58	0,71	66	9	200	100	120	195	100	120	315	47	125	70	78	3-8
EK 350 B	1950	7700	0,81	1,1	86	9	230	65	110	230	65	110	350	51	140	74	83	3-8
EK 400 B	1700	10300	1,1	1,9	122	10	200	70	120	200	70	120	400	56	160	78	88	3-8
EK 440 B	1550	13500	1,4	3	159	10	215	80	130	215	80	130	440	64	180	86	99	5-10
EK 480 B	1400	16600	1,7	4,6	200	10	240	90	145	240	90	145	480	65	190	90	104	5-10